

# MONTAGEANLEITUNG

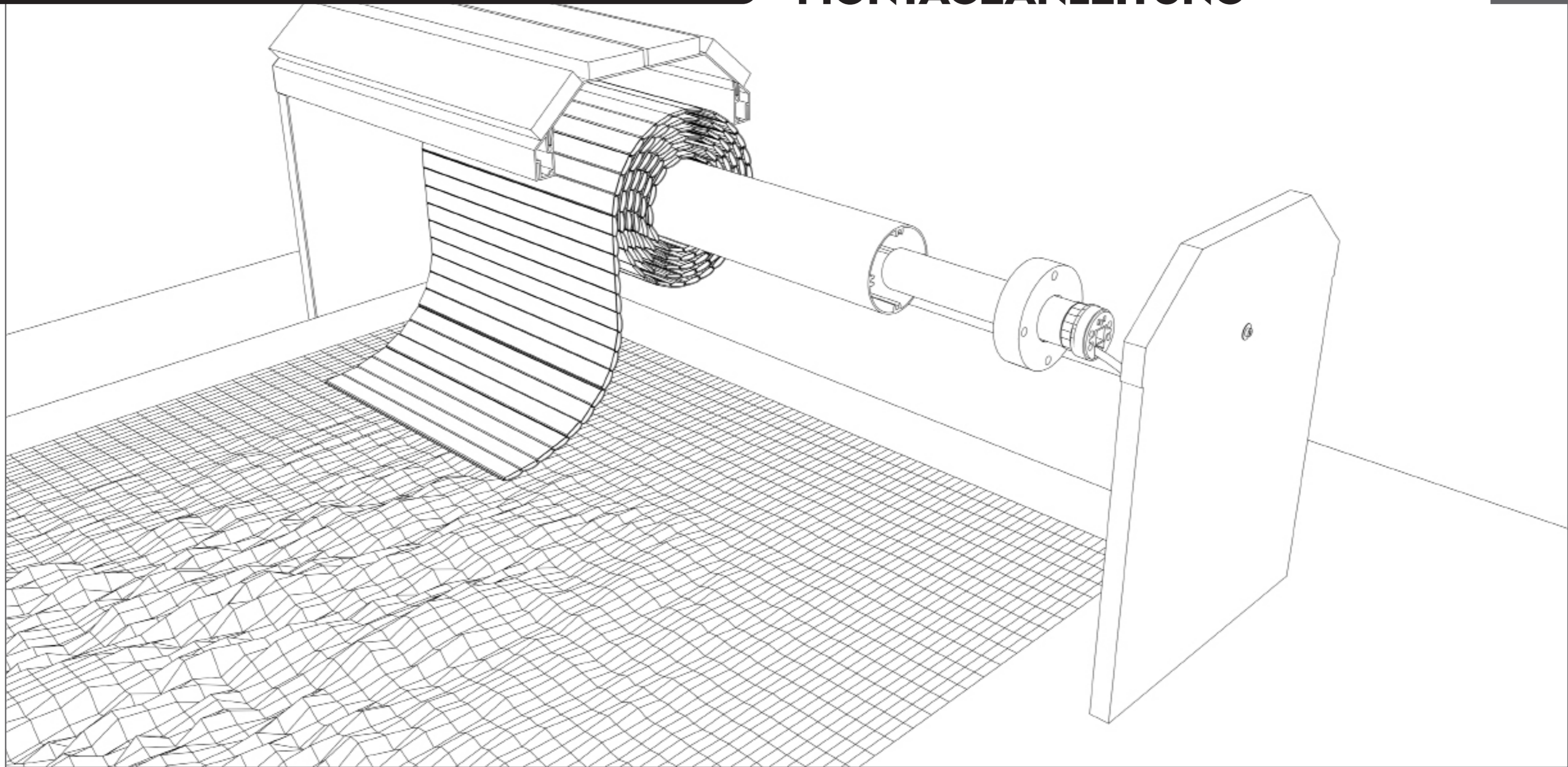

## / DE NOTIZ MONTAGEANLEITUNG

NOTWENDIGE WERKZEUGE NICHT MITGELIEFERT



KUTTER



HANDSÄGE



CLE ALLEN Ø 6



BOHRMASCHINE



SCHRAUBENZIEHER



STECKSCHLUSSEL



STECKSCHLUSSEL



BETONBOHRER



WASSERWAAGE



MASSBAND

**!** BEWAHREN SIE DIE ANLEITUNG AUF AUCH NACH DER INSTALLATION IHRES ROLLADENS

**IHR KIT  
COMPLETE  
EINBAUSATZ  
INKLUSIVE\* :**

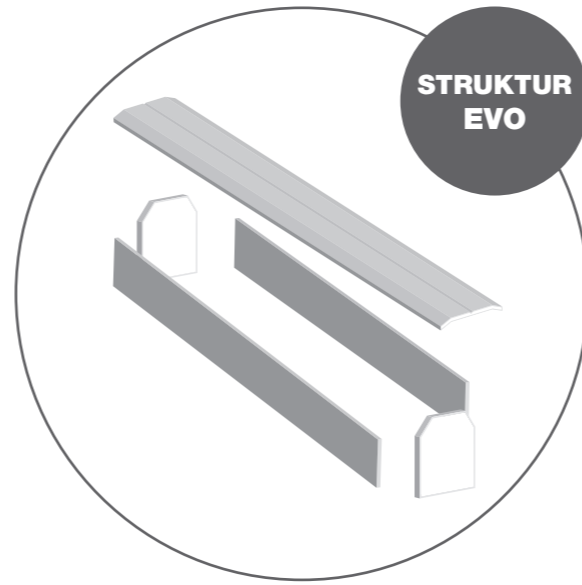

**STRUKTUR  
EVO**

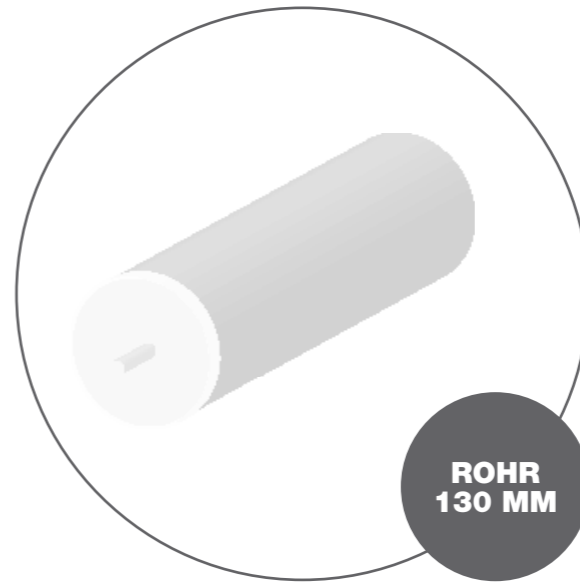

**ROHR  
130 MM**



**ROHR  
165 MM**

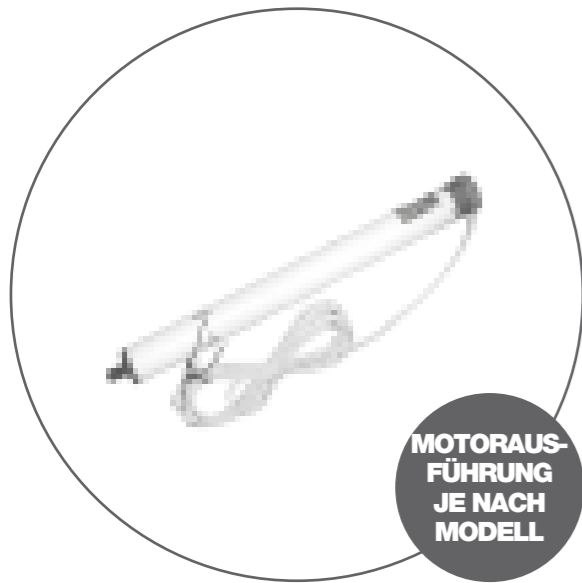

**MOTORAUSSÜHRUNG  
JE NACH  
MODELL**

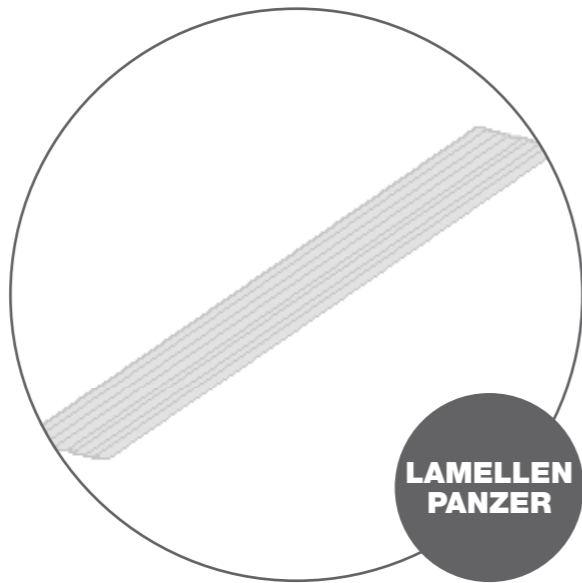

**LAMELLEN  
PANZER**

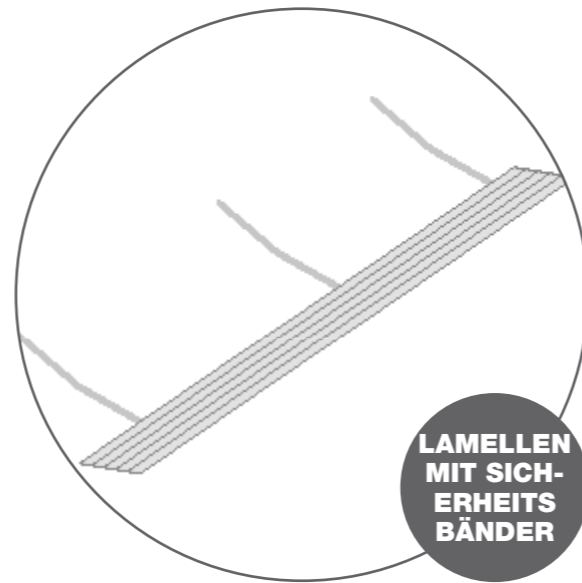

**LAMELLEN  
MIT SICHERHEITSBÄNDER**



**SICHERHEID  
FASSADE  
ODER UNTER  
DEM RANDSTEIN**

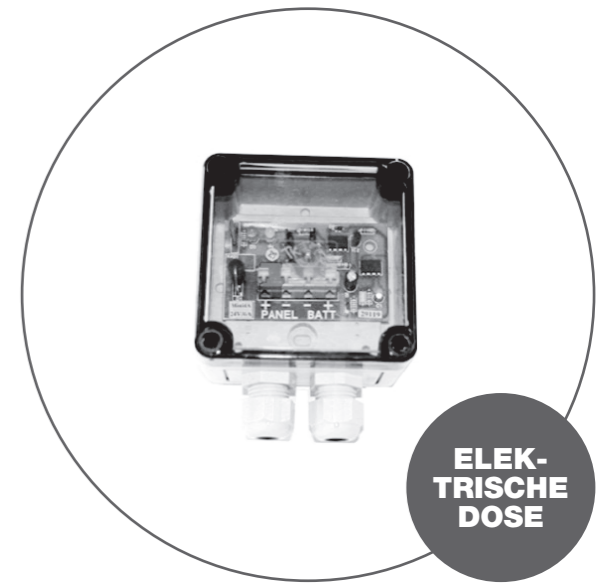

**ELEKTRISCHE  
DOSE**



**BLAUE  
TASTE FÜR  
ENDLAGEEINSTELLUNG**

**+  
SCHRAUBENBEUTEL**

**\*EINIGE TEILE WERDEN JE NACH GEWÄHLTER KONFIGURATION MITGELIEFERT**

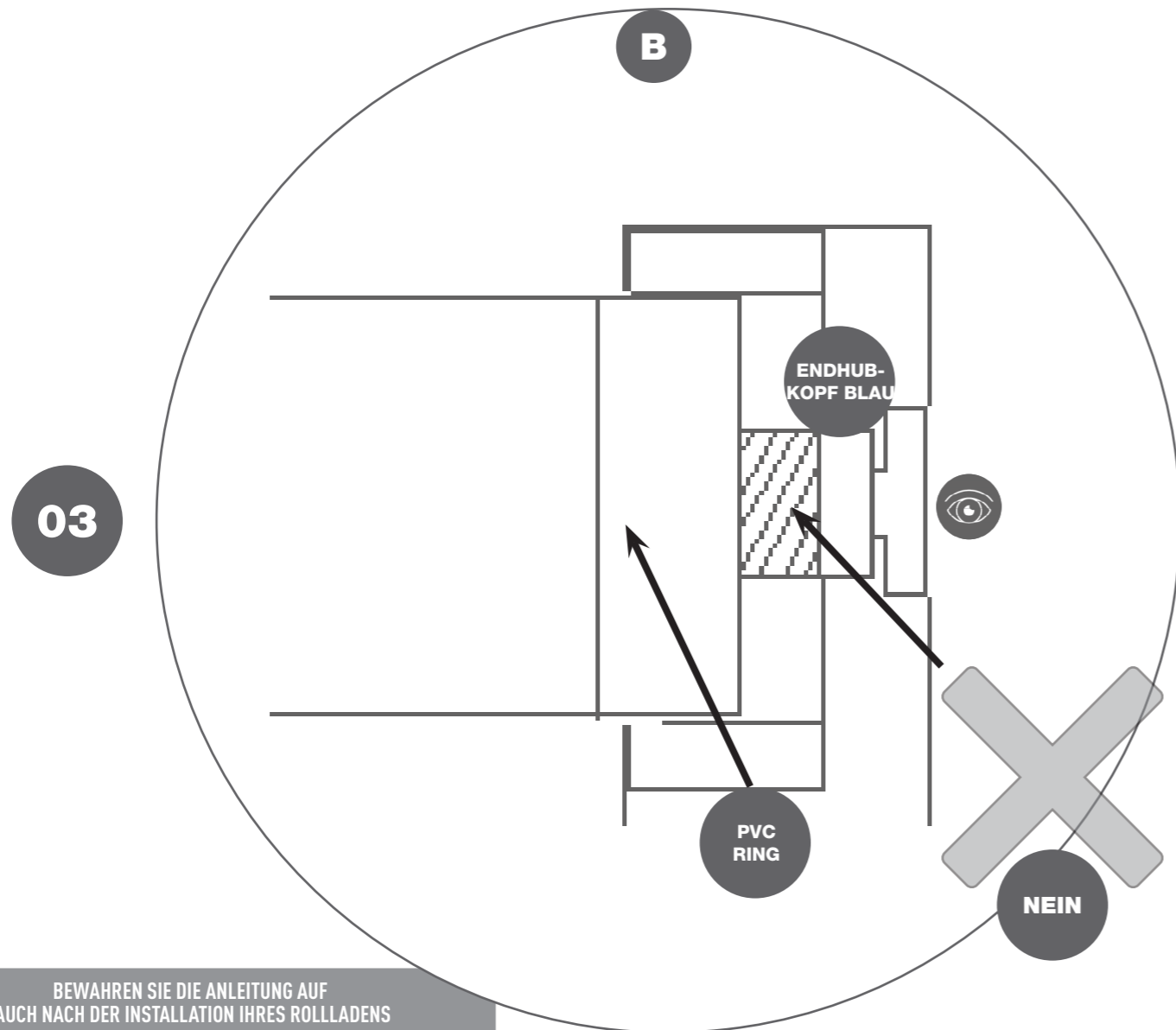
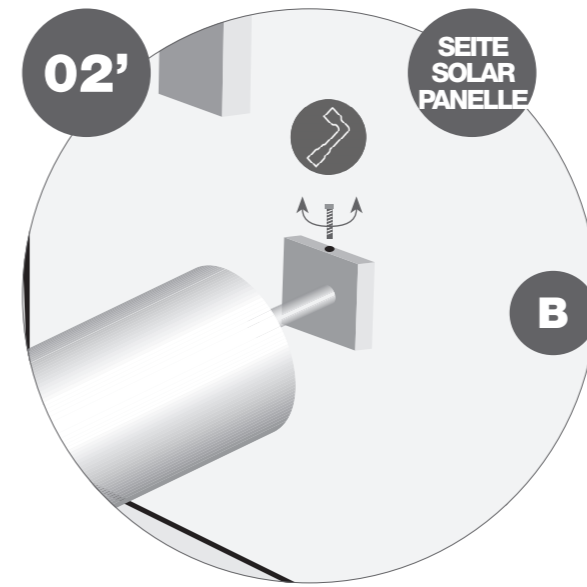
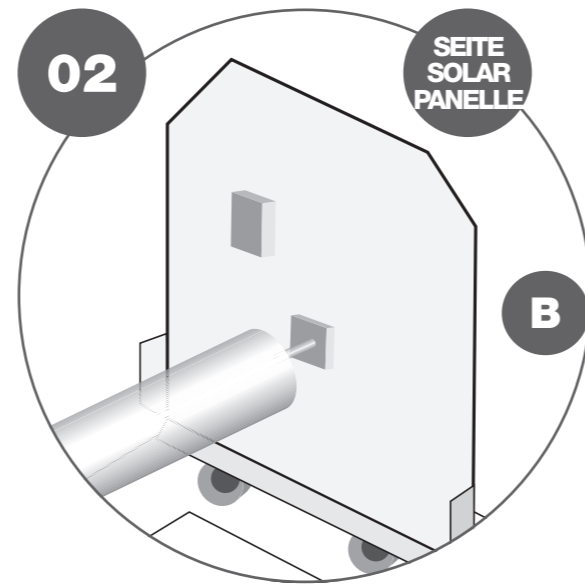
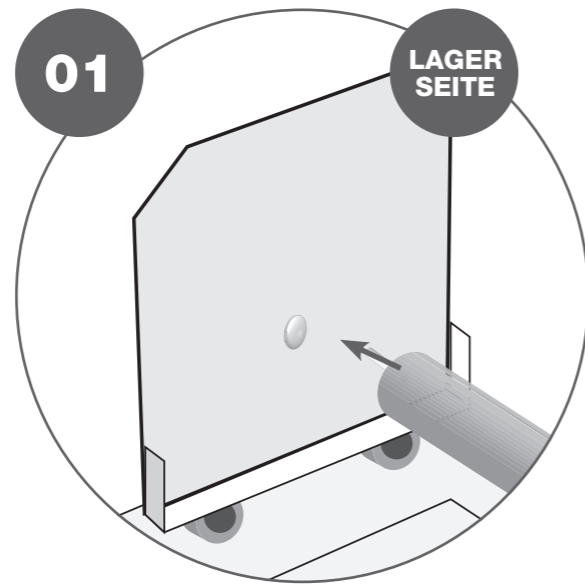

MOTOR-SEITE

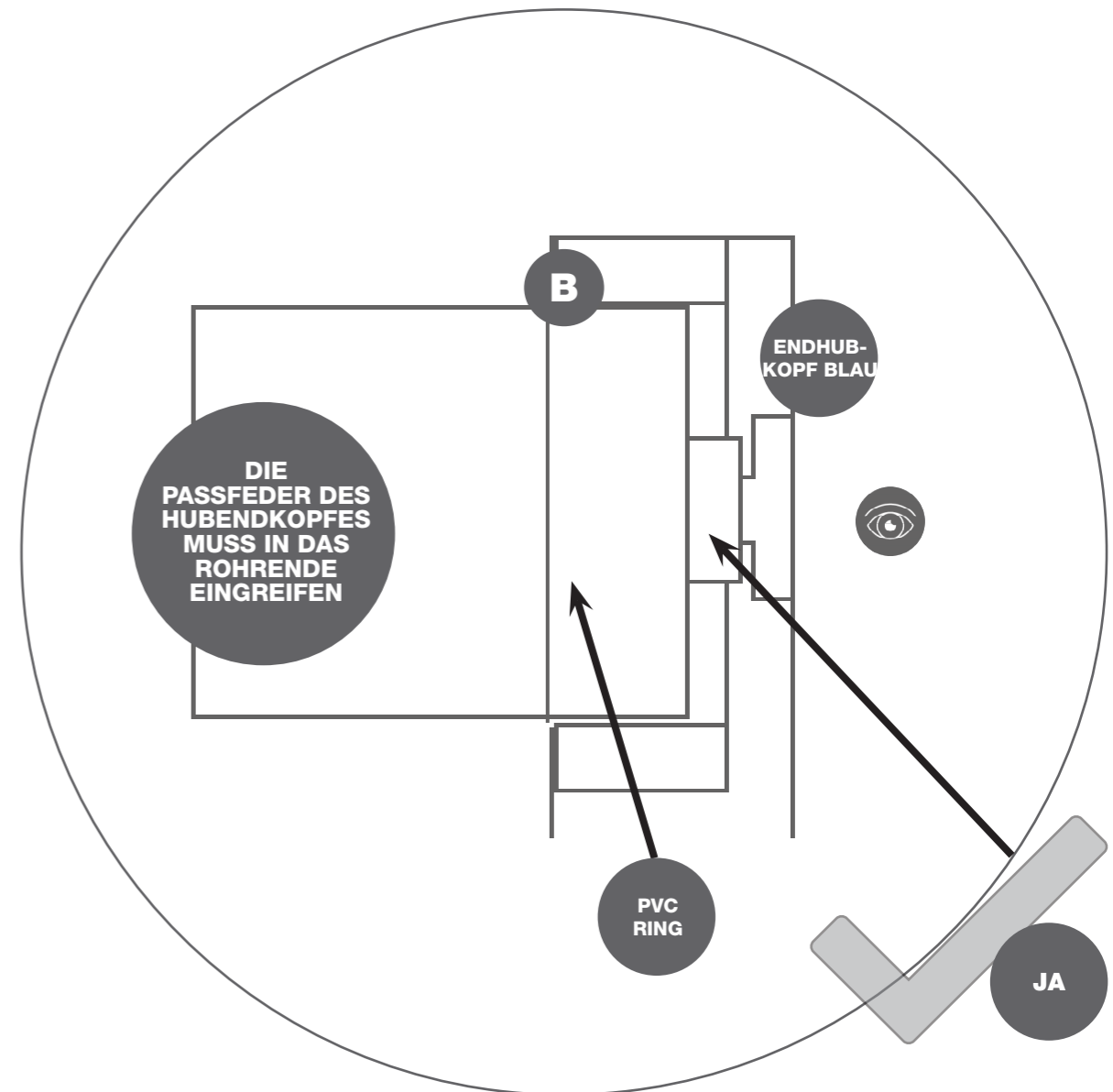

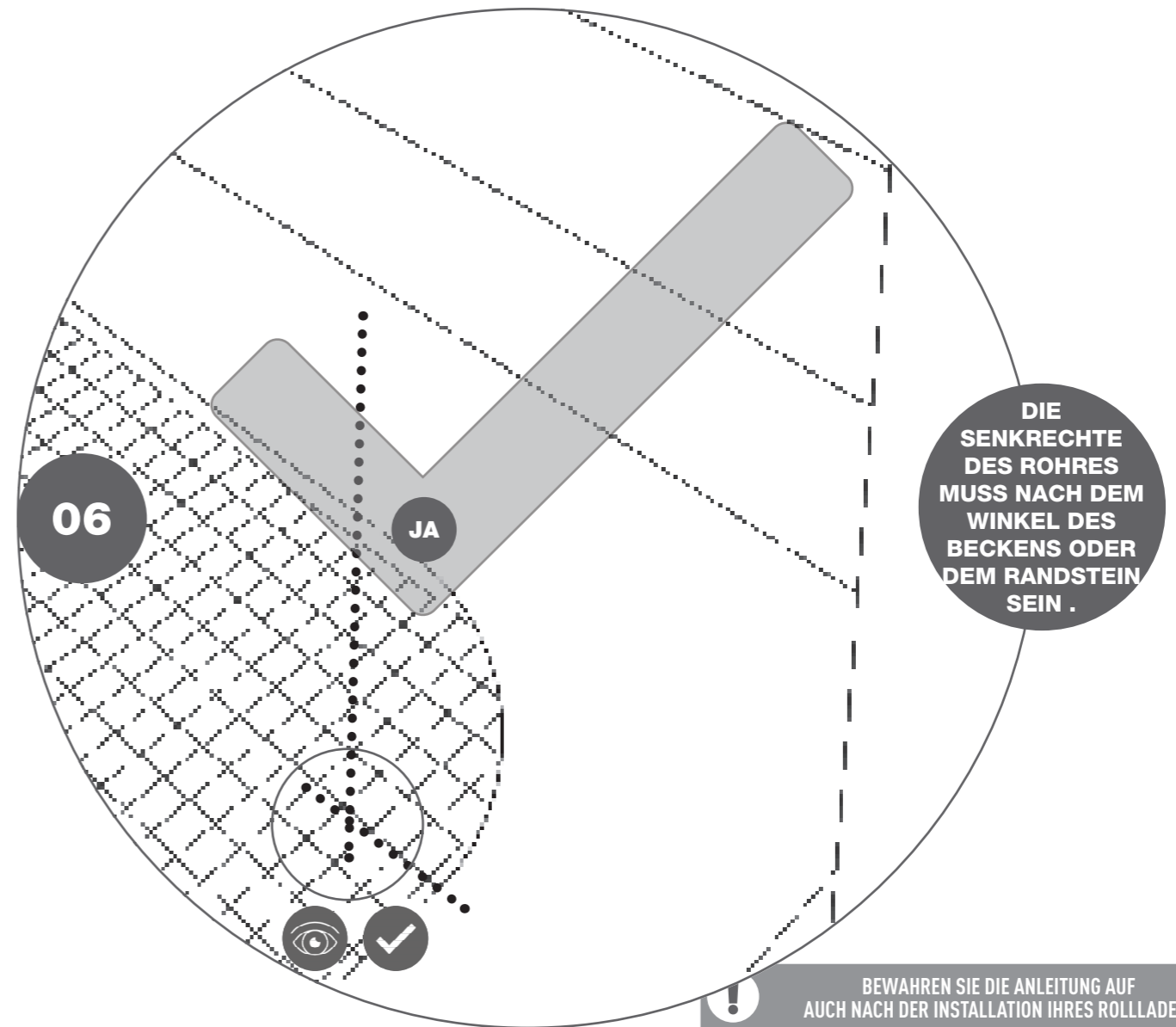
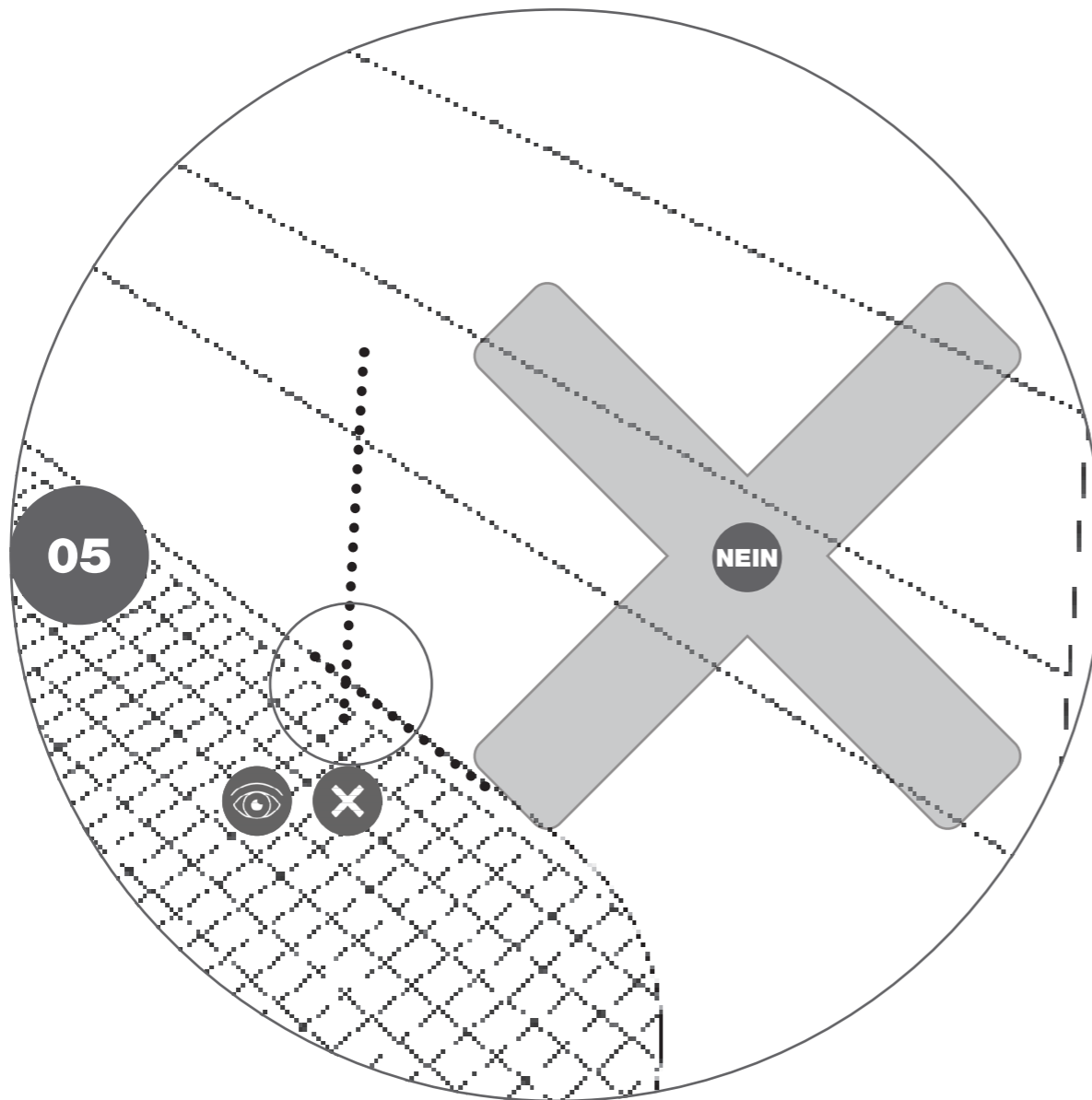
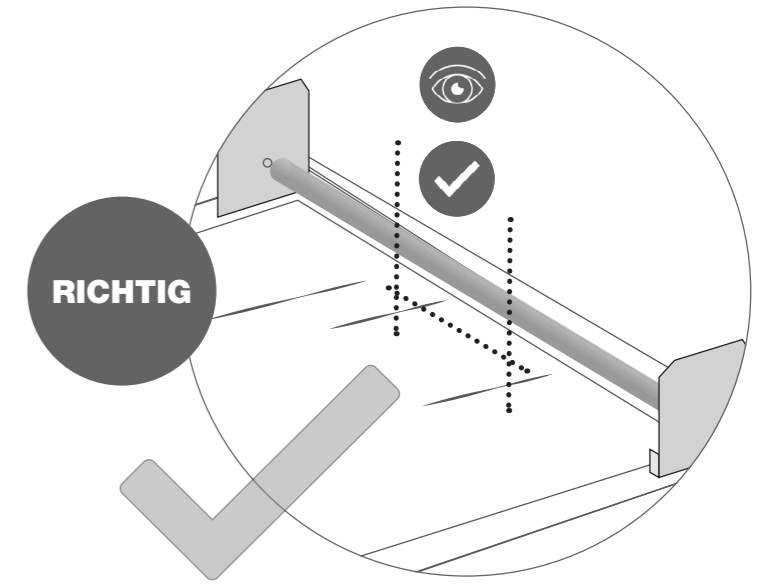
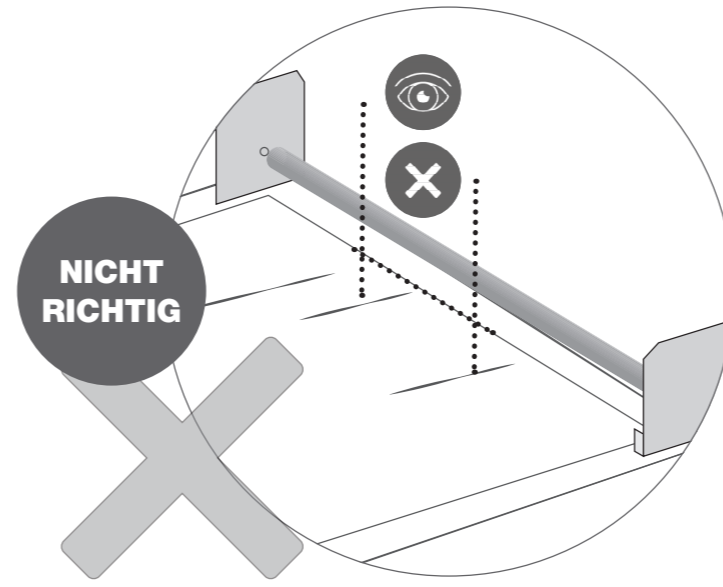
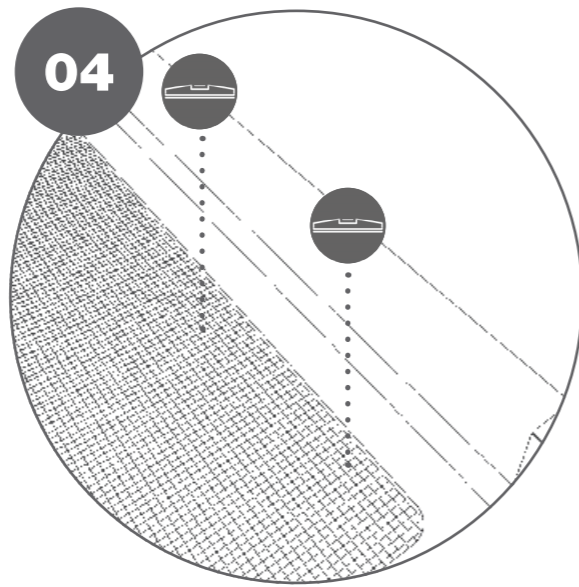

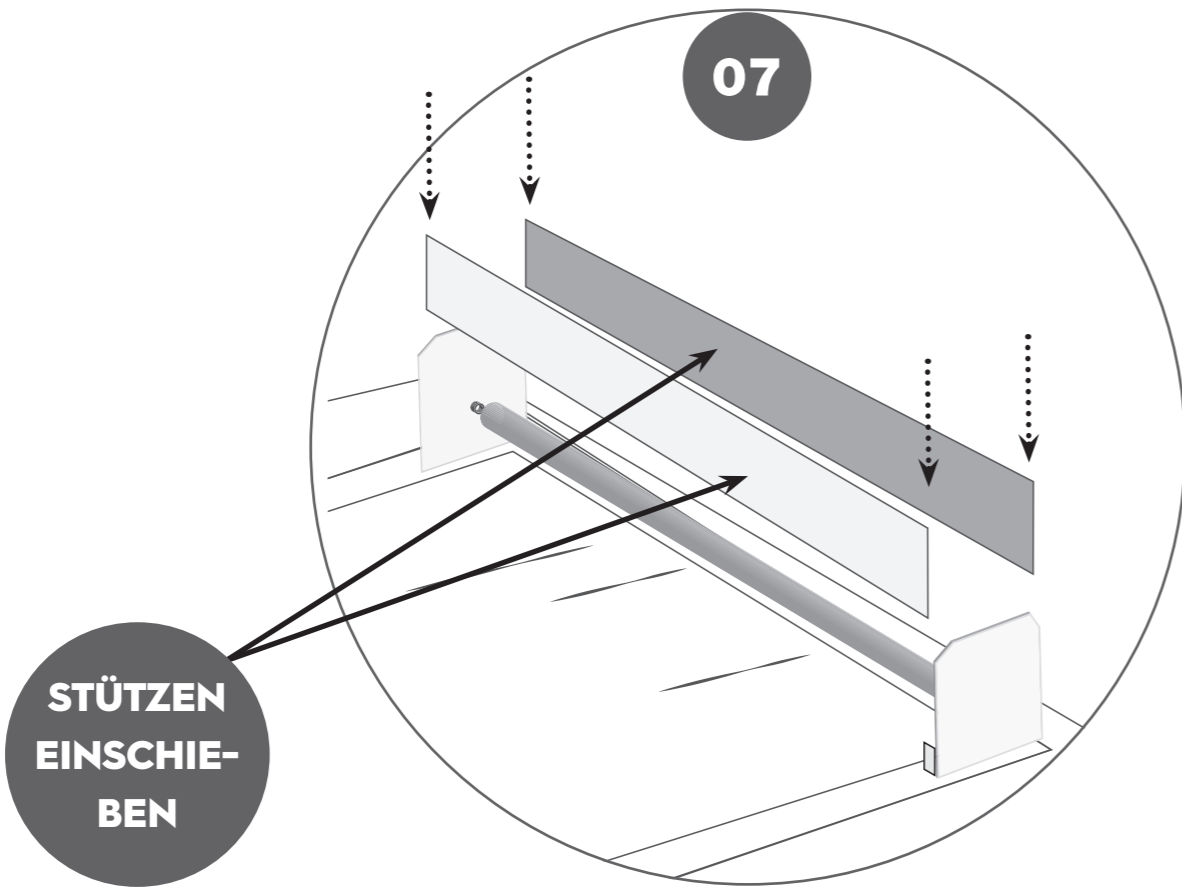

ANTSARREN  
AUF DEM  
BODEN

X 2

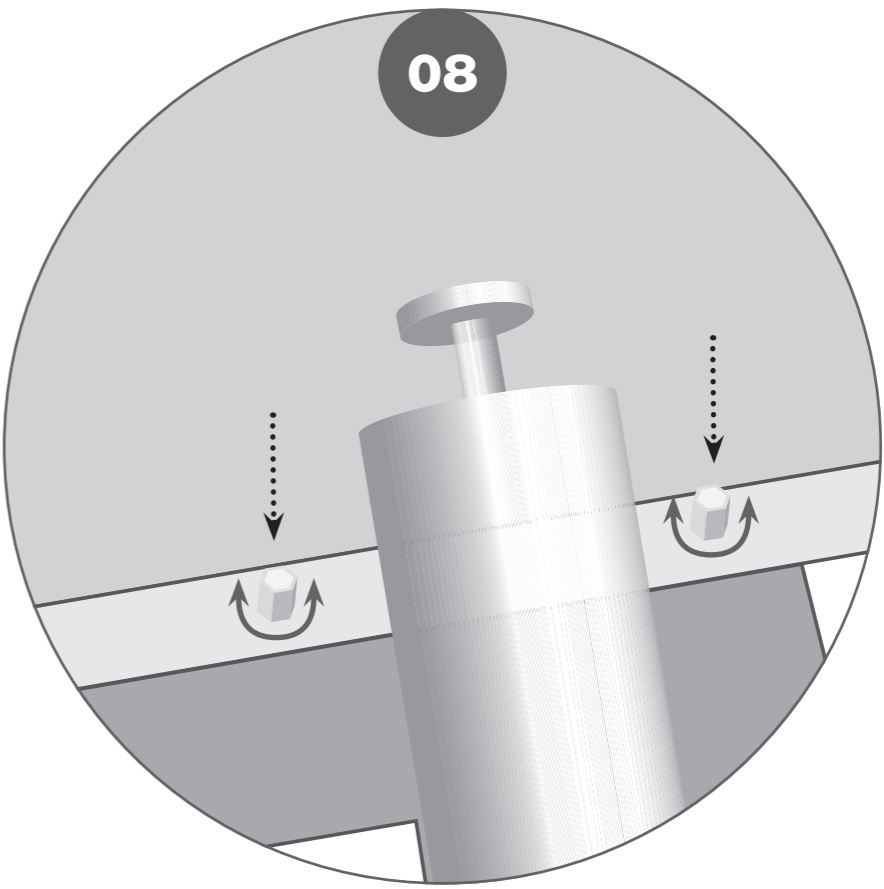

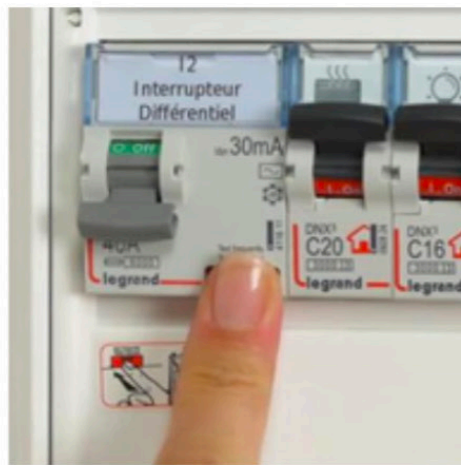

**KUNDEN-  
ELEKTROSCHALTSCHRANK  
ELEKTRISCHER SCHUTZ  
30mA-Sicherung + 10A-  
SCHALTER**

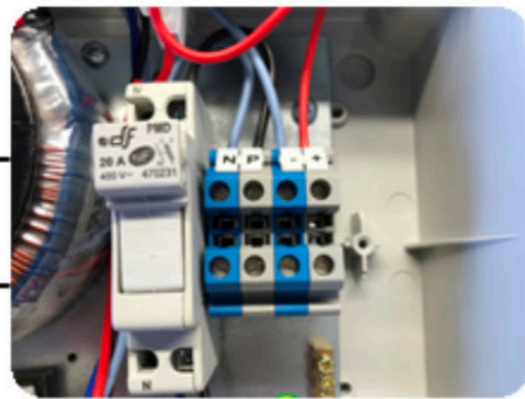

**OBERFLURSCHRANK  
STROMVERSORGUNG 230V  
ÜBER KLEMME N & P  
START 24V ÜBER KLEMME + & -**

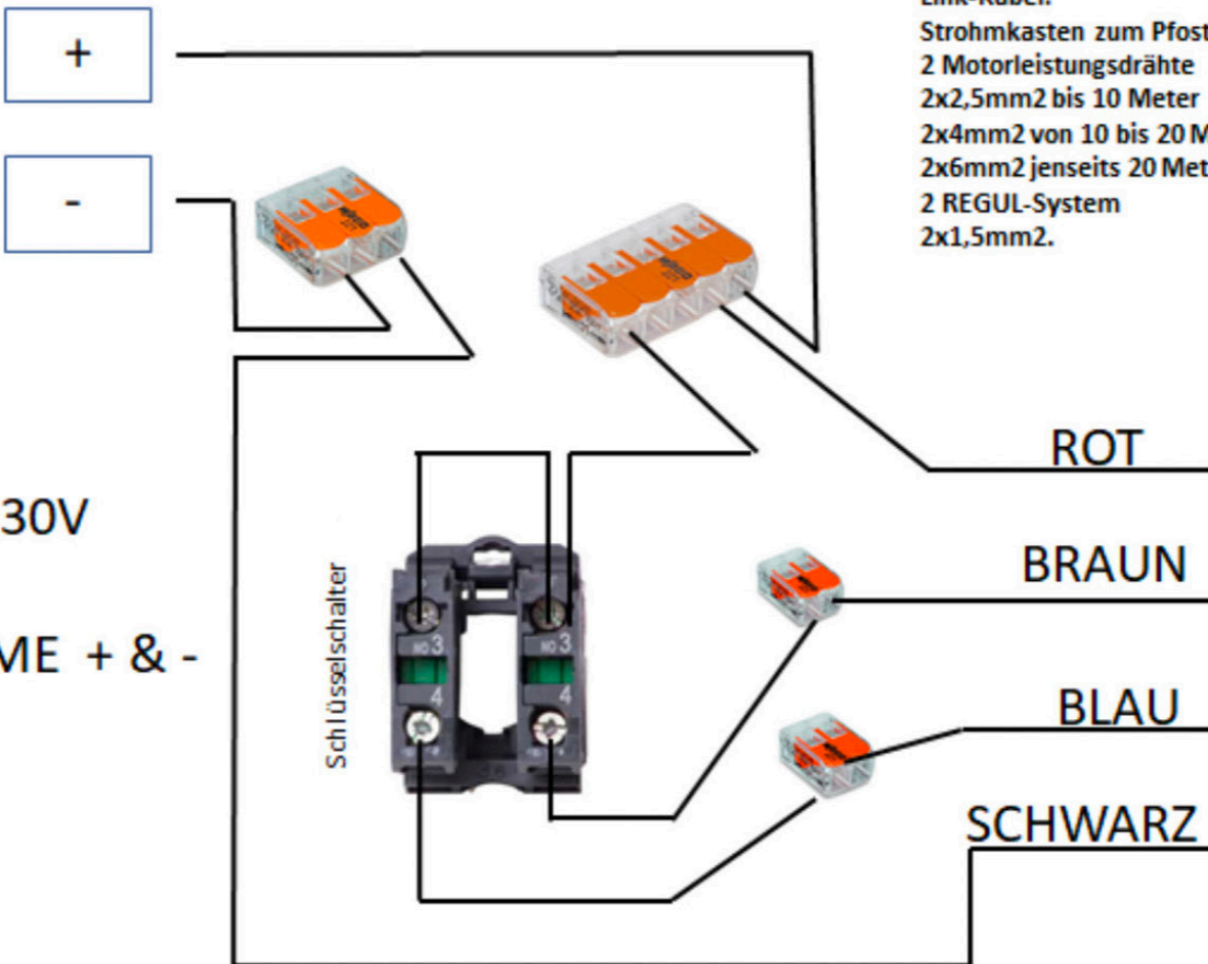

**MOTOR PFOSTEN**

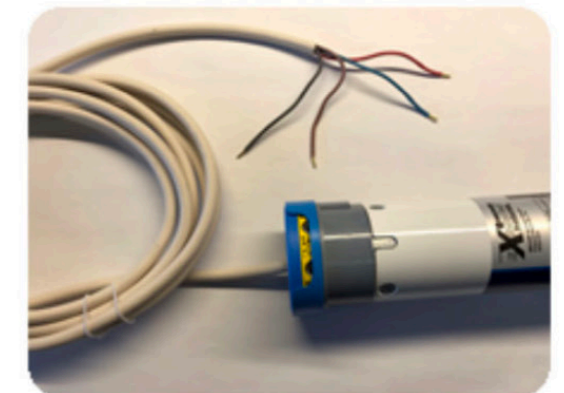

**OBERFLUR MOTOR**



**NEHMEN SIE IHRE  
ENDSCHALTEREINSTELLUNG  
N VOR, SIE DIE FUNK- ODER  
BLUETOOTH-AUSRÜSTUNG  
INSTALLIEREN.**

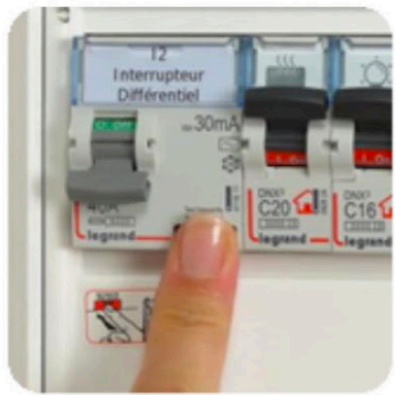

**KUNDEN-  
ELEKTROSCHALTSCHR  
ANK**

**ELEKTRISCHER  
SCHUTZ**  
30mA-Sicherung +  
10A-SCHALTER

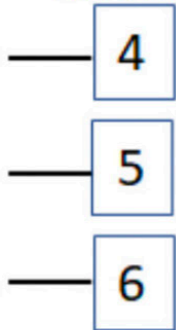

KLEMMEN Nr. 4 = Kontakt N zur Behandlung  
KLEMMEN Nr. 5 = Kontakt NF zur Behandlung  
KLEMMEN Nr. 6 = Gemeinsam zur Behandlung  
KLEMMEN Nr. 1 = Öffnung nach Schlüssel  
KLEMMEN Nr. 2 = Negativer 24-V- Rollladen Schranck  
KLEMMEN Nr. 3 = Schließen nach Schlüssel

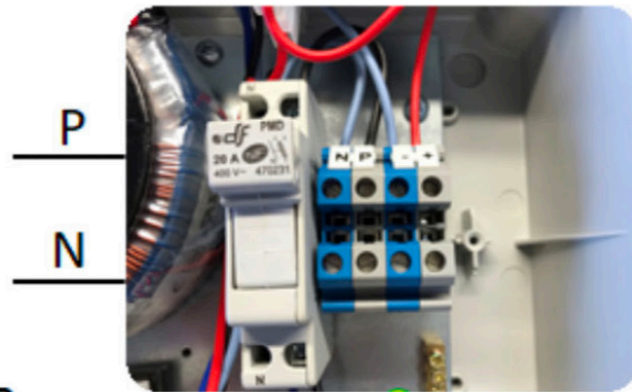

**OBERFLURSCHRANK  
STROMVERSORGUNG  
230V**  
ÜBER KLEMMEN N & P  
START 24V ÜBER  
KLEMMEN + & -



NEGATIF 24V

2 3

1

ZURÜCK SCHLIESSEN

ZURÜCK ÖFFNEN

COMMUTATEUR A CLE

Link-Kabel:  
Stromkasten zum Pfosten  
2 Motorleistungsdrähte  
2x2,5mm<sup>2</sup> bis 10 Meter  
2x4mm<sup>2</sup> von 10 bis 20 Metern  
2x6mm<sup>2</sup> jenseits 20 Meter  
2 REGUL-System  
2x1,5mm<sup>2</sup>.

ROT

BRAUN

BLAU

SCHWARTZ



**MOTOR PFOSTEN**

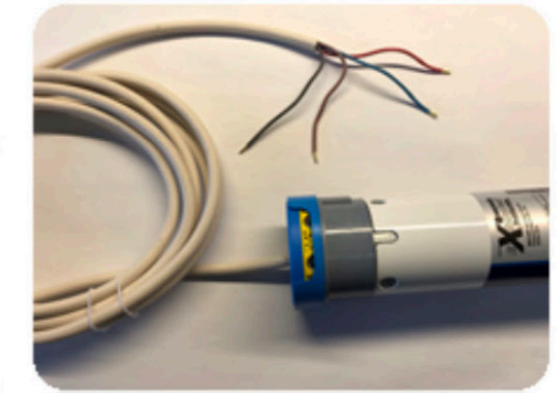

**OBERFLUR MOTOR**

## OPTION REGUL SYSTEM - ANSCHLUSS

Bluetooth

ENDABSCHALTUNG  
EINSTELLEN BEVOR SIE  
DIE BLUETOOTH KARTE  
EINSTEKEN UND

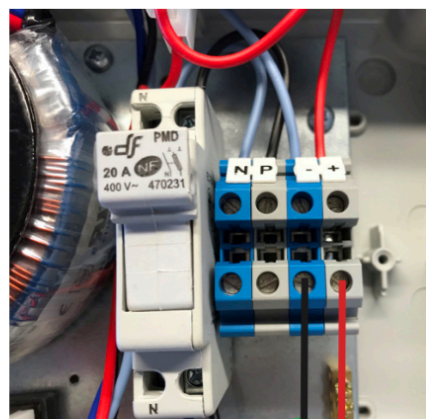

SCHALTSCHRANK

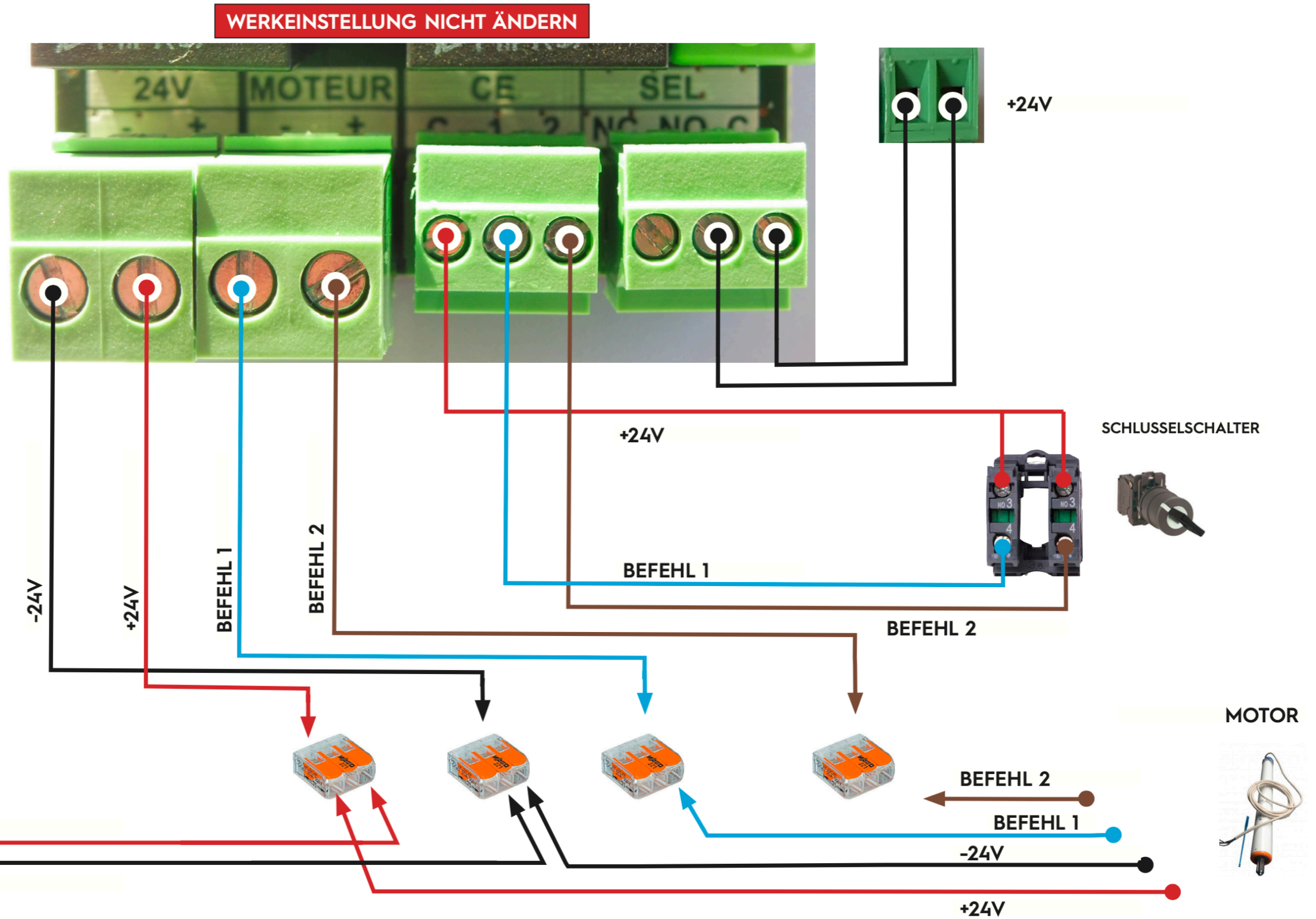

CONSERVEZ LA NOTICE  
MÊME APRÈS L'INSTALLATION DE VOTRE VOLET



**MONTAGE  
VON DEN  
LAMELLEN**

08

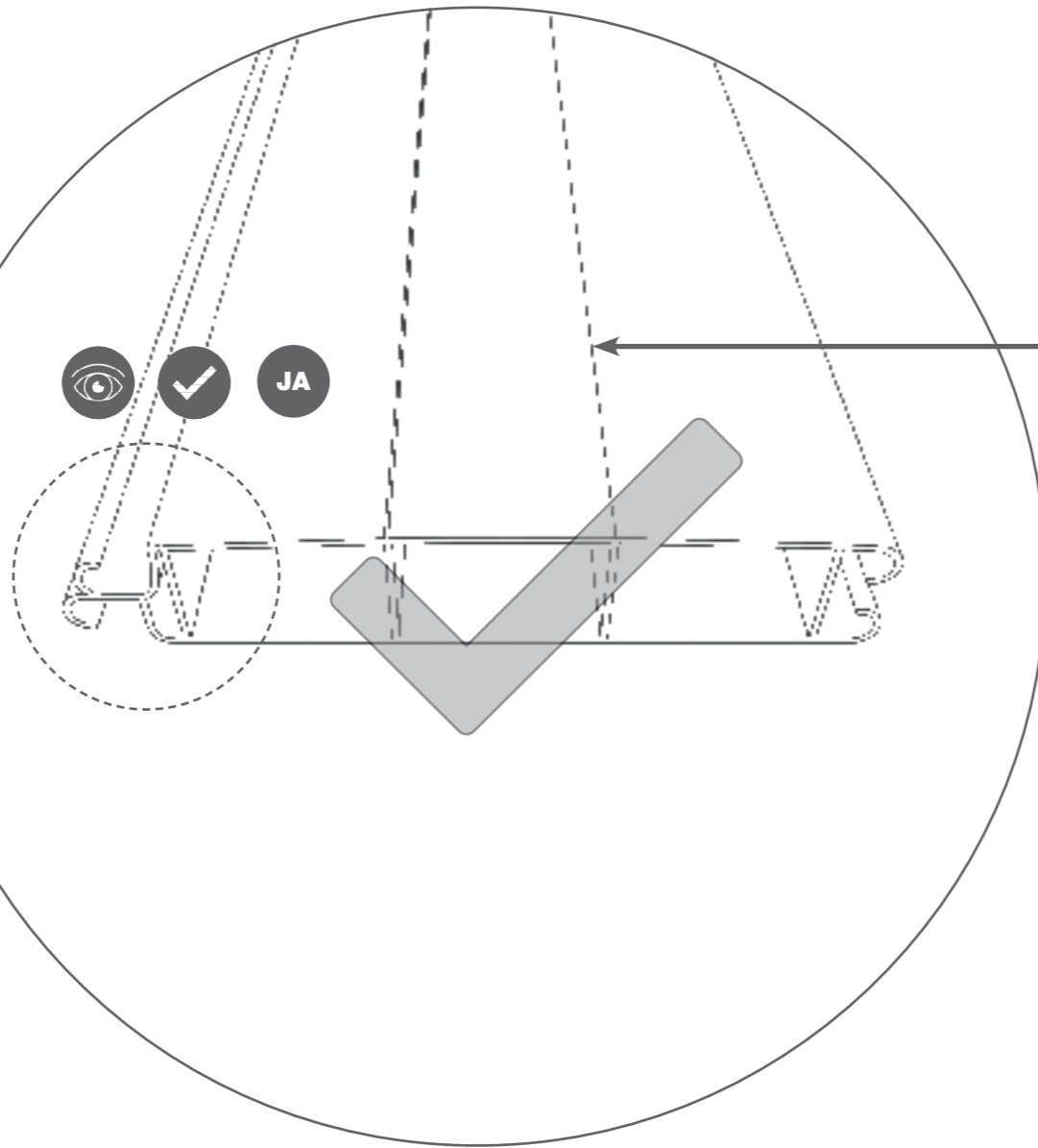

**LAMELLENRILLEN  
AUF DER  
OBERSEITE**

09

1

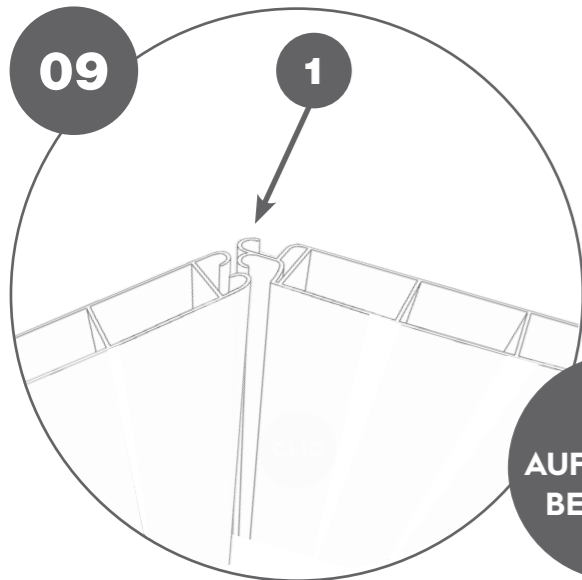

10

2

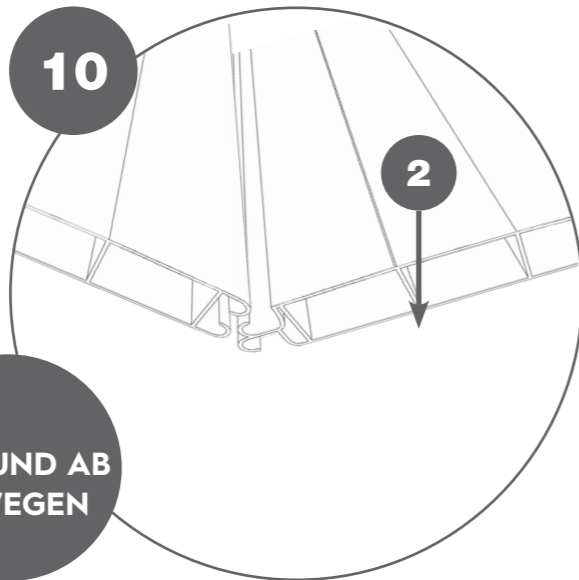

**AUF UND AB  
BEWEGEN**

11

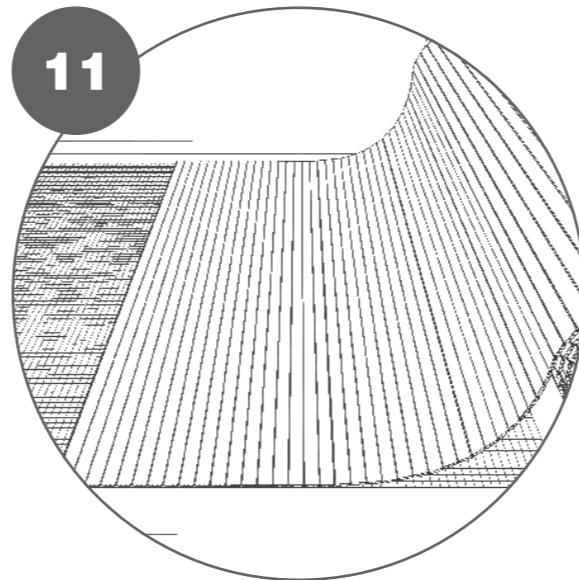

12

ø10

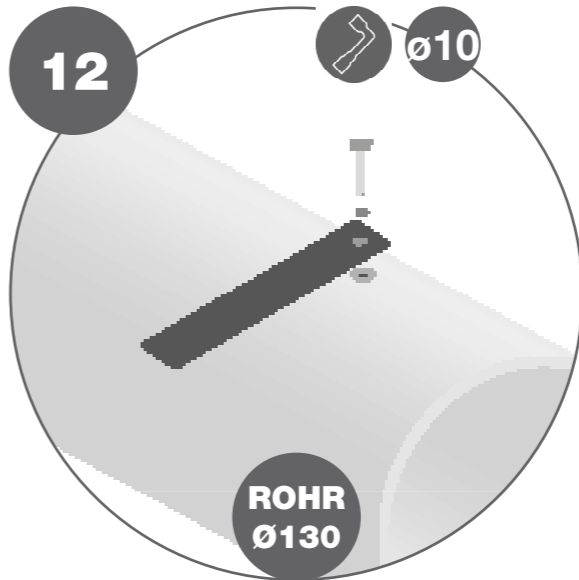

12'

ø13

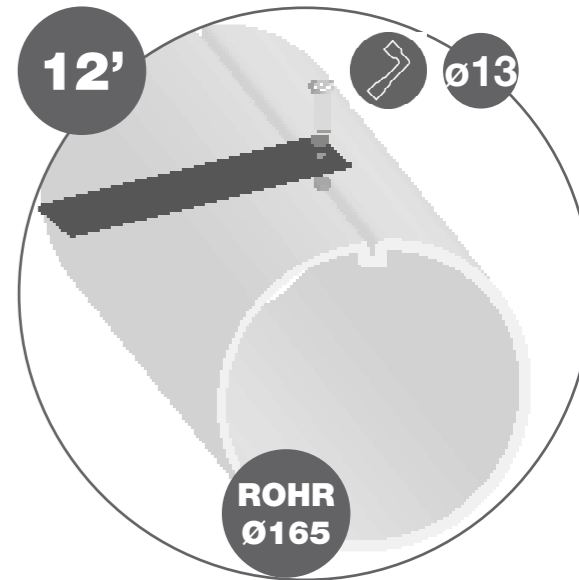

**ROHR  
Ø130**

**ROHR  
Ø165**

# AUFHÄNGUNG EINER RÖMISCHEN TREPPE

13

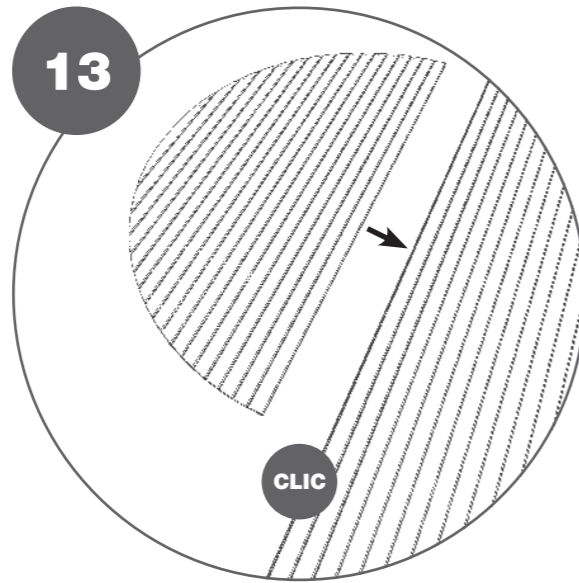

14

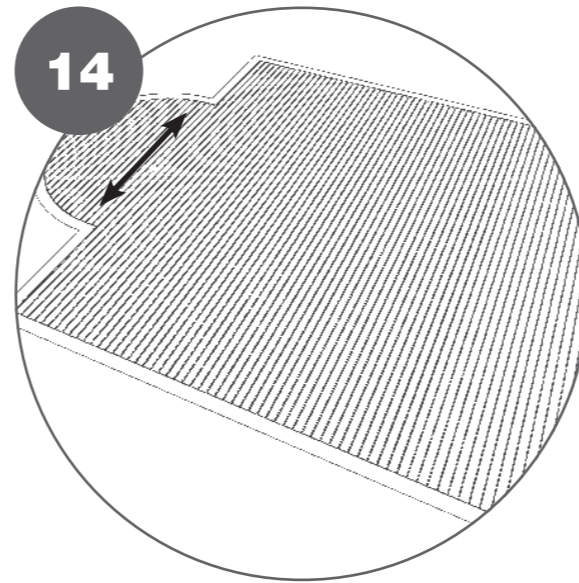

15

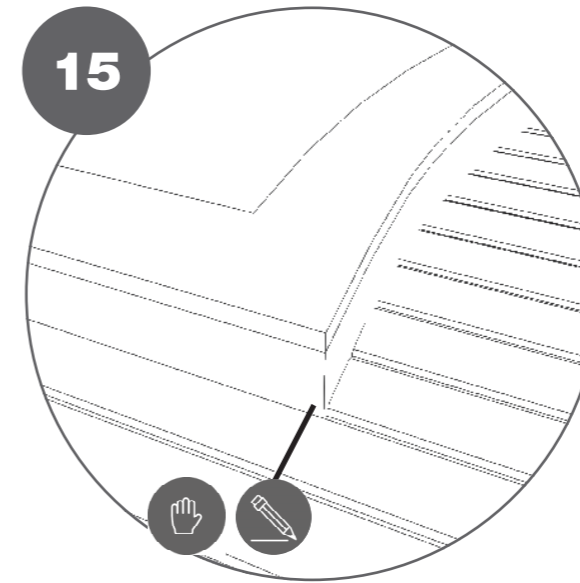

16

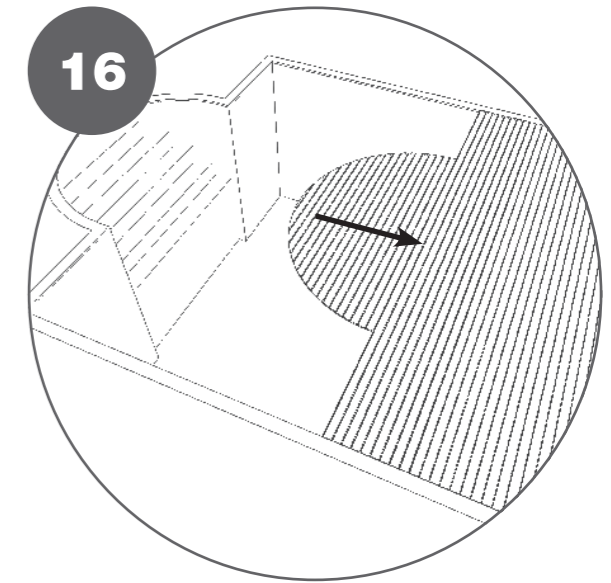

17

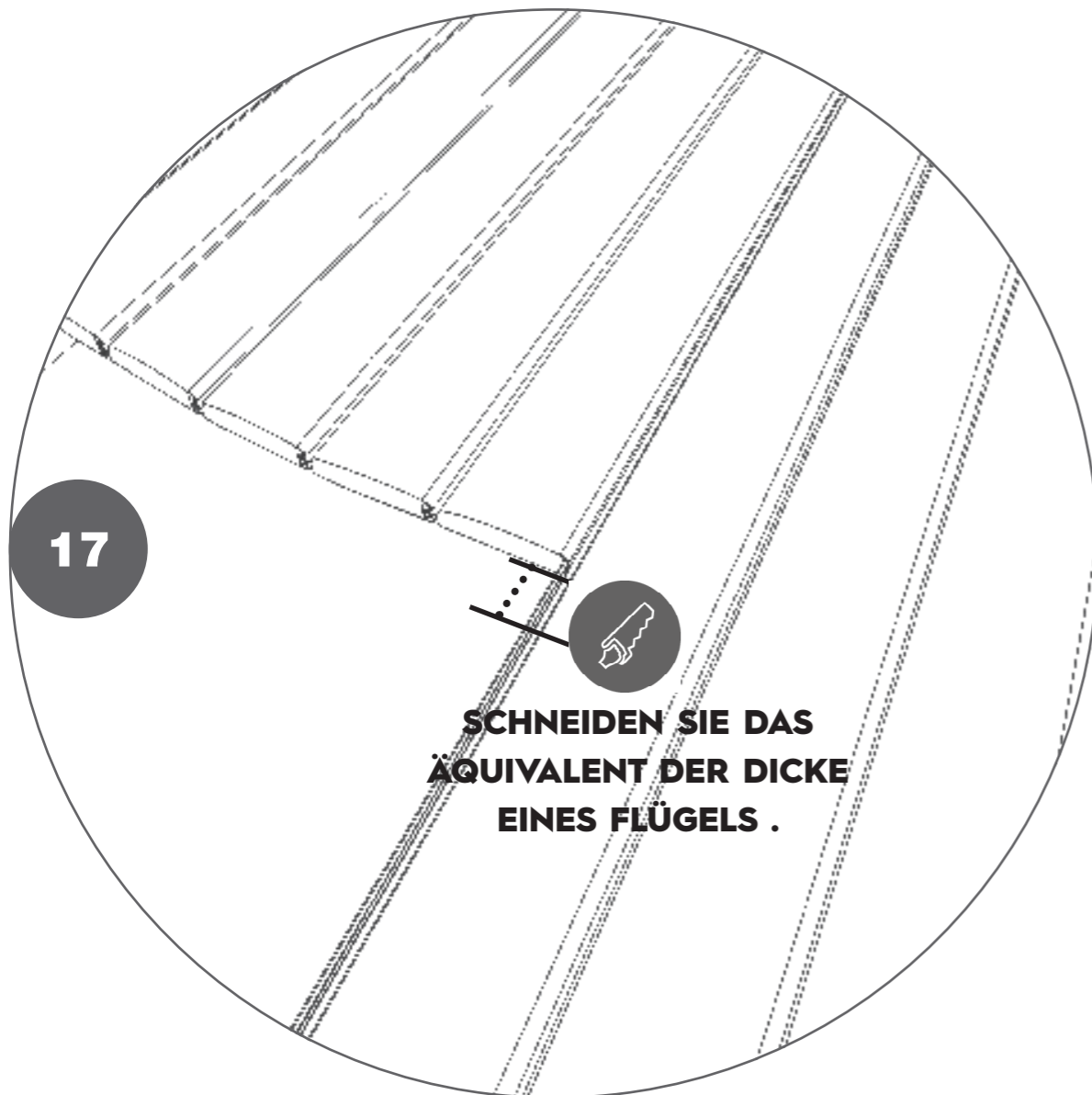

SCHNEIDEN SIE DAS  
ÄQUIVALENT DER DICKE  
EINES FLÜGELS .

18

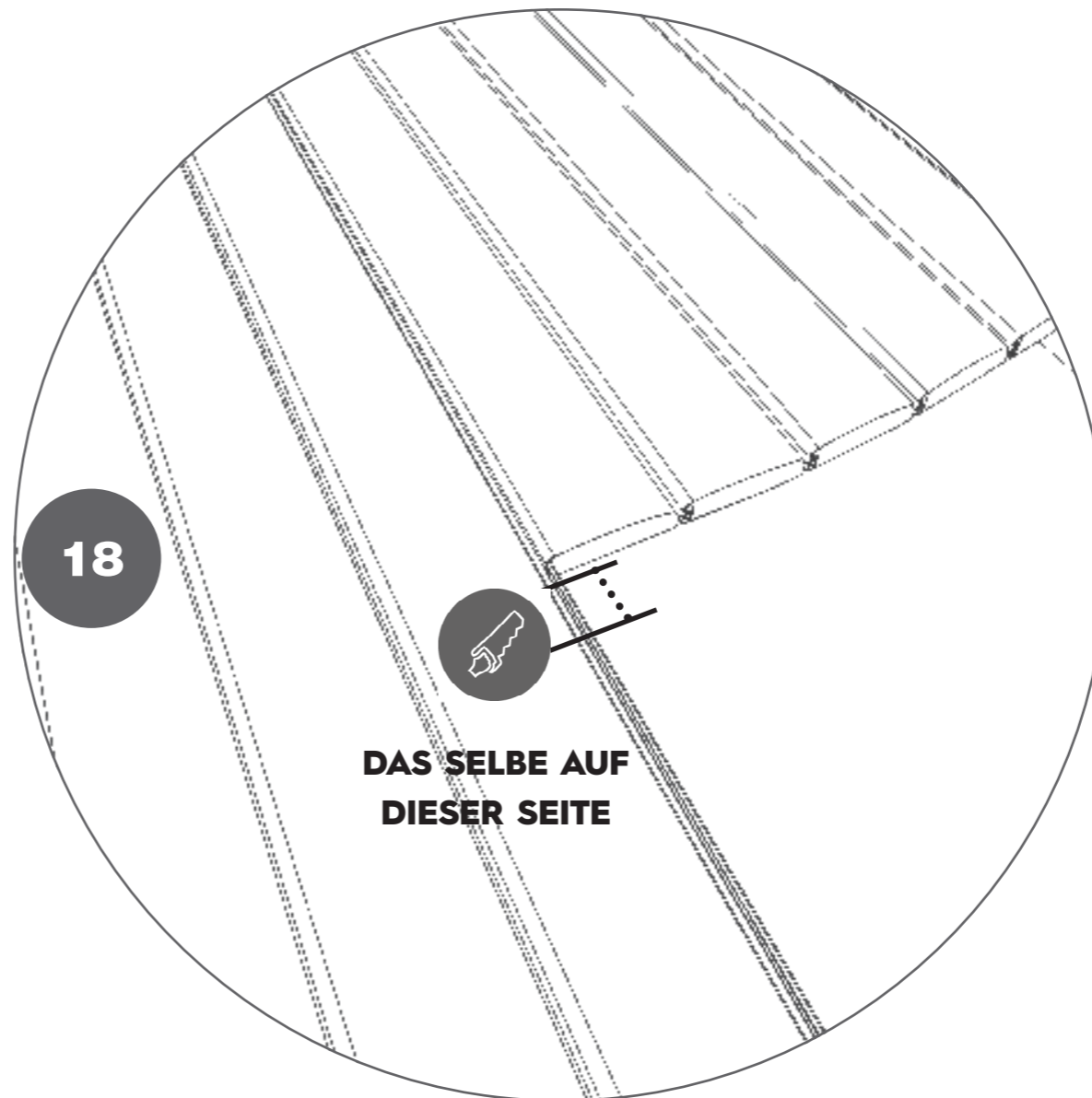

DAS SELBE AUF  
DIESER SEITE

19

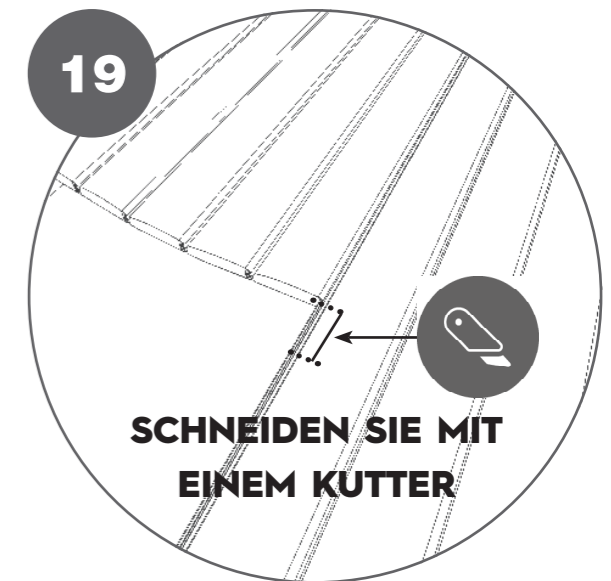

SCHNEIDEN SIE MIT  
EINEM KUTTER

**PRÜFUNG UND  
EINSTELLUNG  
VON  
ENDSCHALTERN**

**LAMELLEN  
PANZER AUF  
DAS BECKEN**

20

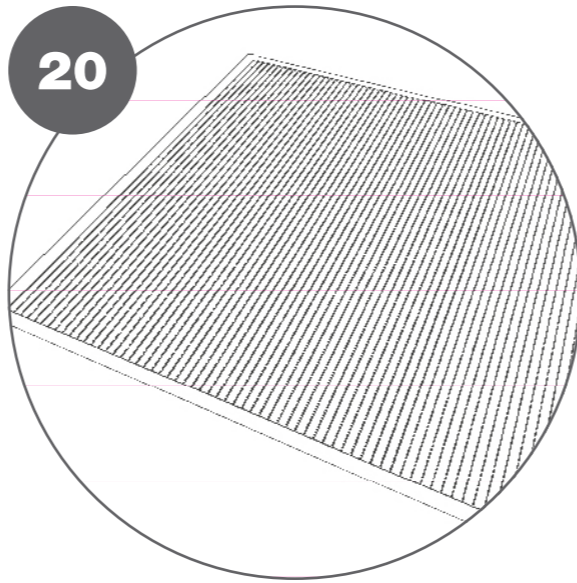

**DREHEN SIE DIE  
AUFROLLWELLE  
OHNE LAMELLEN  
IN DIE GESCHLOS-  
SENE POSITION**

21

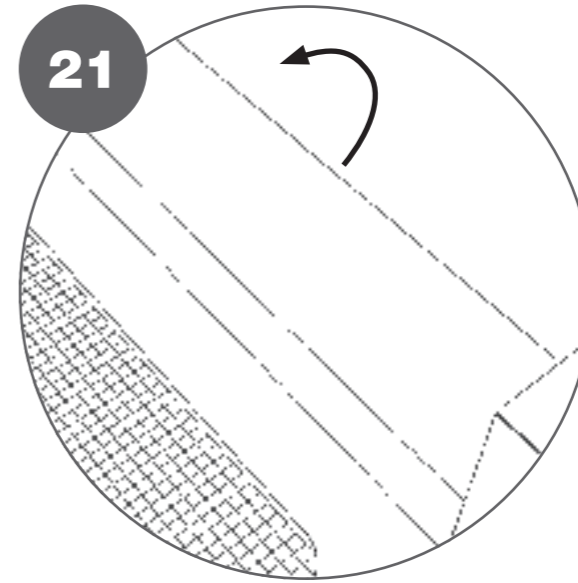

**... BIS ZUM  
STILLSTAND  
VON DEM  
ROHR**

22

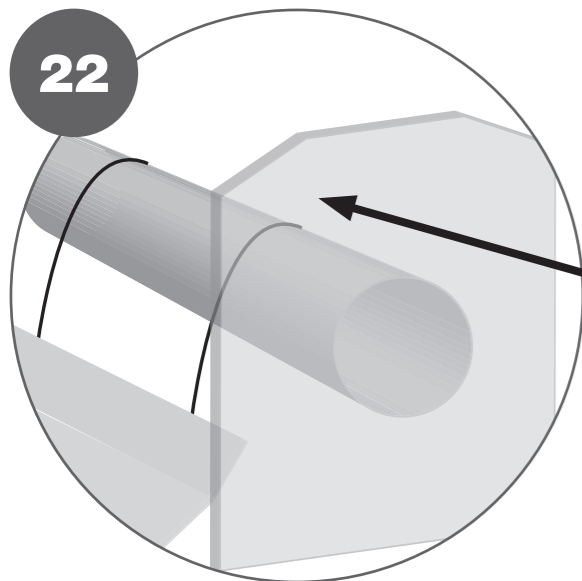

**DANN DIE  
GURTE  
ANBRINGEN  
UND IN DER  
SPANNUNG  
EINSTELLEN**

**ÖFFNUNG  
EINSTELLEN**

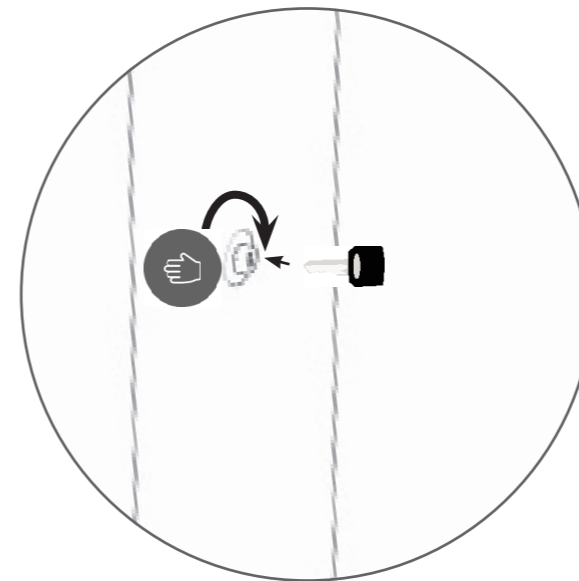

**DREHEN SIE  
DEN SCHLÜSSEL  
IN ÖFFNUNG-  
RICHTUNG, BIS DER  
ROLLADEN  
ANHÄLT**

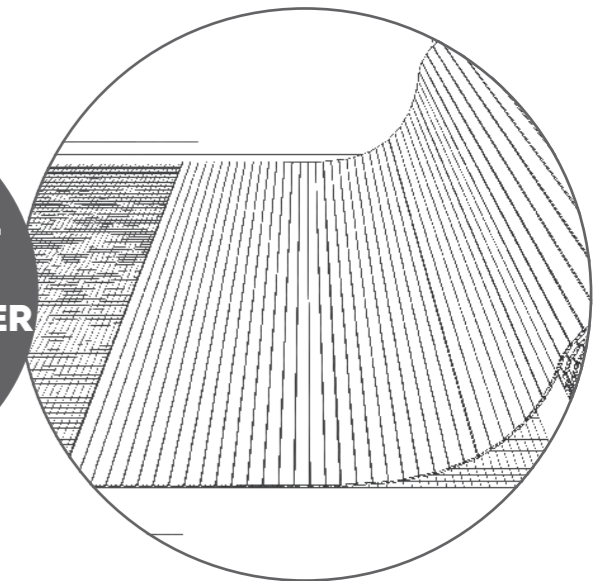

**WENN DER  
VORHANG VOR  
DEM ENDE ANHÄLT  
MÜSSEN SIE ES  
EINSTELLEN**

23

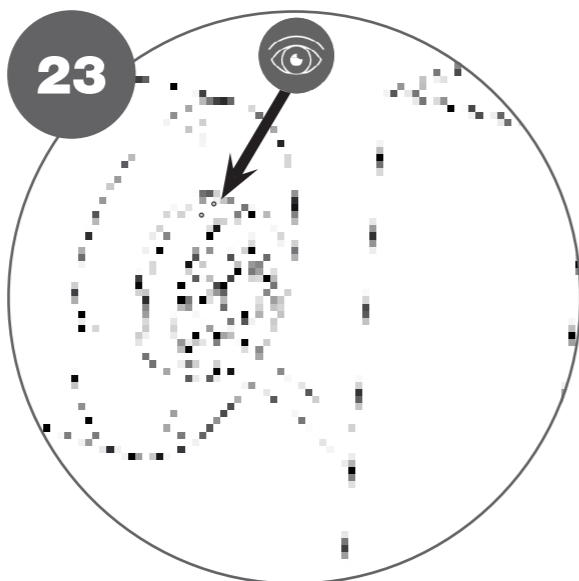

24

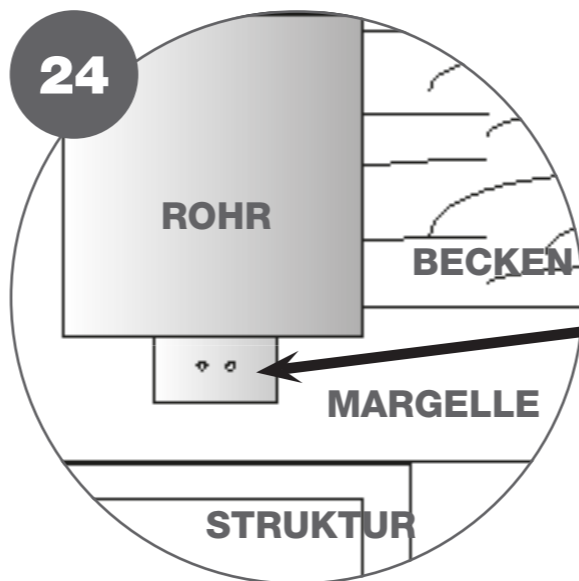

ZOOM

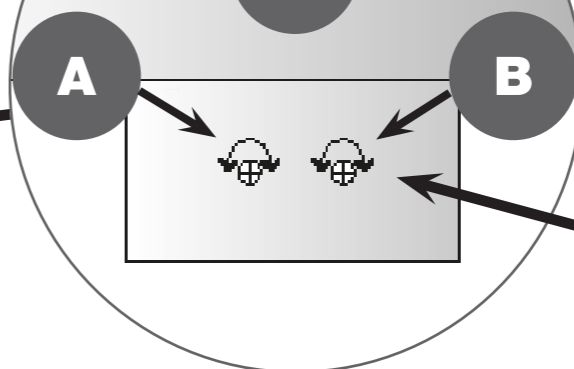

**MIT  
HILFE DEM  
BLAUEN  
SCHLÜSSEL**

**EINSEL-  
LUNG DER  
SCHRAUBE  
A ODER B**

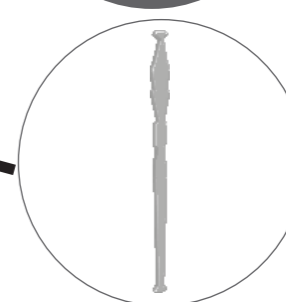

**KEIN ELE-  
KTRISCHER  
SCHRAUBER  
NEHMEN**

25

WENN SIE VOR DEM MOTOR STEHEN :  
WENN DER MOTOR LINKS VON DEM BECKEN IST NEHMEN SIE DIE SCHRAUBE A

WENN DER MOTOR RECHTS VON DEM BECKEN IST NEHMEN SIE DIE SCHRAUBE B UM ES EINZUSTELLEN ;

26

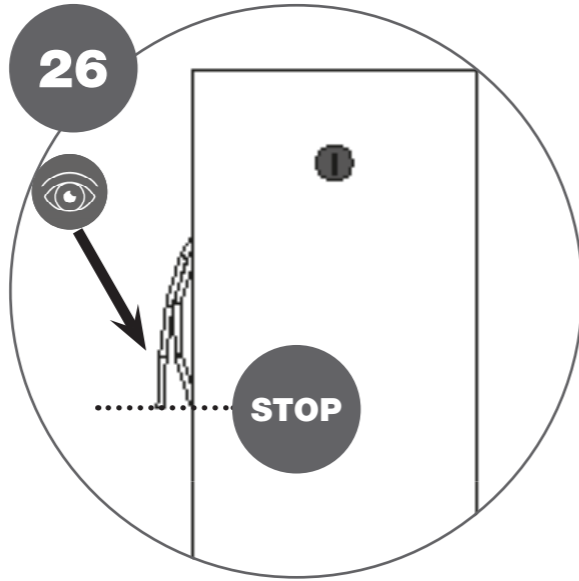

27

DIE SCHRAUBE VON DEM ROHR 130 ODER DIE EINFÜHRUNG VON DEM ROHR 165 MUSS IMMER SO WIE AUF DEM BILD STEHEN DAS HEISST NACH UNTEN .

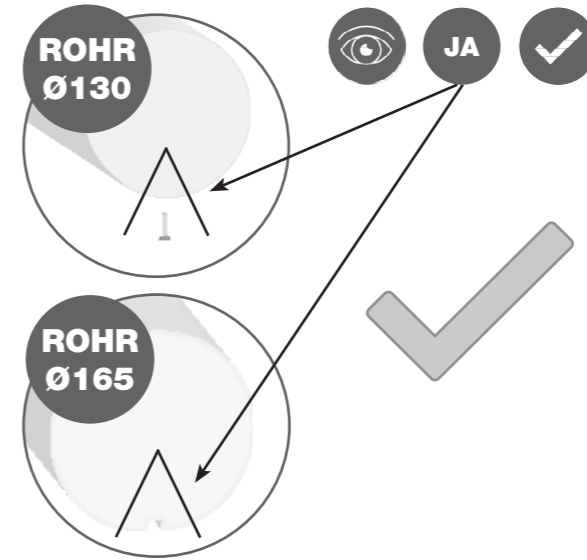

LEGE  
DIE  
SCHRAUBE

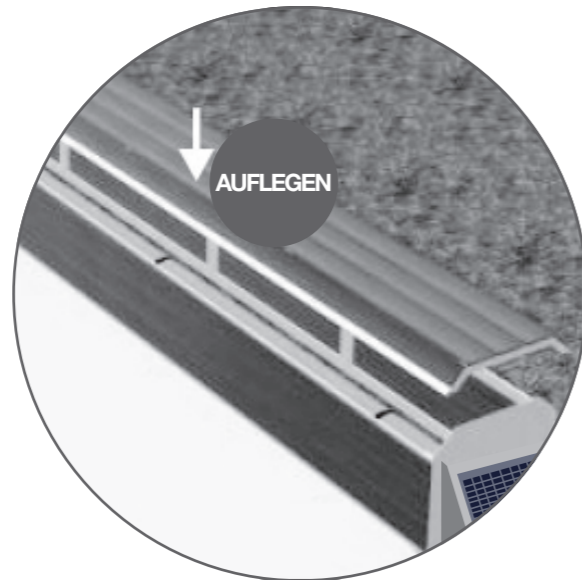

SCHRAUBEN SIE DEN DECKEL EVO AN DEN WINKEL

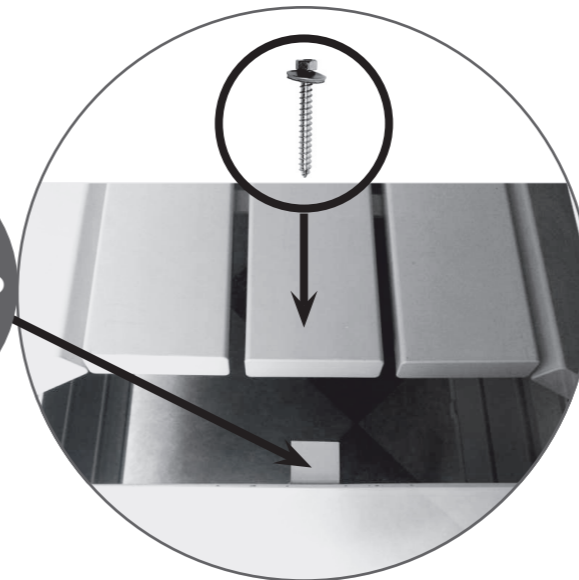

SISCHERHEIT SYSTEM

